

FILTER CHARACTERIZATION SYSTEM



PERFORMANCE

ANGLE OF INCIDENCE CALIBRATION

- Uncertainty 0.3° for angles between $\pm 15^\circ$

SPECTRAL LINE POSITION CALIBRATION

- Atmospheric spectrum or NIST standard reference material
- Error < 0.5 nm from 2 to 5 μm

FILTER TEMPERATURE CALIBRATION

- Diode calibration accuracy ± 0.5 K
- Temperature stability 0.1 K (1 standard deviation)

CONTAMINATION MONITORING & ANALYSIS

- In-situ QCM
- Analysis of measured spectra
- Consistent, stable outgassing rate (water)
 - Minimal build-up, no impact on transmittance measurements

OVERVIEW

PRECISION INFRARED (IR) SPECTRAL FILTER CHARACTERIZATION

- Cryogenic temperature (90 K typical)
- High spatial resolution (0.5 mm)
- Variable angle of incidence ($\pm 15^\circ$)

FOURIER TRANSFORM IR (FTIR) SOURCE

- High spectral resolution (2 cm^{-1} typical)

LARGE CAPACITY FILTER WHEEL

- Enables spectral testing of up to eleven filters per cold cycle
- Each filter position can accommodate
 - 1" round filters
 - Multiple smaller filters

VARIABLE F# TO MATCH TEST REQUIREMENTS

IN-SITU FILTER TEST ADJUSTMENTS

- X & Y position
- Focus
- Angle of incidence

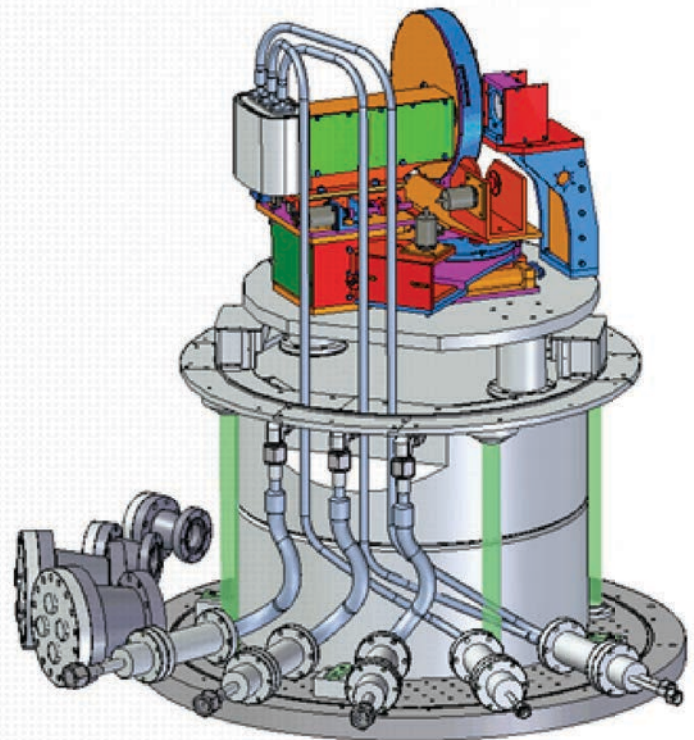

Space Dynamics
LABORATORY
Utah State University Research Foundation